



200S Patient Stander - Steel

USER MANUAL



IMPORTANT:

Do not use the ASPIRE 200S Stander without having first read this manual.

TABLE OF CONTENTS

1. Overview _____	3
2. Safety Precautions _____	4
3. Parts Glossary _____	6
4. Assembly _____	7
5. Preliminary Checks _____	9
6. Stander Operation _____	9
7. Standing Guide _____	13
8. Sling Compatibility _____	14
9. Care & Maintenance _____	15
10. Warranty & Service _____	16
11. Troubleshooting _____	17
12. Specifications _____	18
13. Service Log Book _____	20

1. OVERVIEW

The ASPIRE 200S is an ergonomically designed mobile stander with a generous safe working load (SWL) of 200kg.

This mobile stander is ideally suited as a familiar and reliable solution for institutional and aged care environments.

The ASPIRE 200S stander allows patients to be transferred from sitting to standing and vice versa with comfort and safety.

The proven bull horn shape yoke offers versatility in patient grip points and multiple sling hooks to meet various user and carer needs. The height and width adjustable knee pads offer lower leg comfort and security during the lift.

The ASPIRE range of patient handling solutions feature industry leading LINAK Jumbo Care electronics and have been designed and tested to comply with AS/NZS ISO 10535:2011.



2. SAFETY PRECAUTIONS

INTENDED USE OF THE PRODUCT

The ASPIRE 200S Stander has been designed to stand and transfer human patients with the assistance of one carer or attendant.

All ASPIRE patient standers should ONLY be used with Aidacare approved patient slings, which have been chosen and assessed by a competent trained health professional. For a complete list of all compliant lifting slings please contact Aidacare on 1300 133 120.

IMPORTANT – only approved slings and accessories are compatible with this stander. If you are unsure please contact Aidacare on 1300 133 120.

The correct and appropriate use of the ASPIRE 200S Stander reduces the risks associated with manual patient handling. The transferring of patients should always be assessed and planned by a trained health professional.



This is the direction of travel for which this stander has been designed.

SAFETY CONSIDERATIONS

ALWAYS ensure that attendants have read this guide before operating this patient stander.

ALWAYS use slings that are assessed and considered suitable by a trained healthcare professional.

ALWAYS ensure the area around the stander and patient is clear of obstructions.

ALWAYS minimize the distance over which the patient is being transferred by positioning support surfaces as close as possible.

DO NOT operate the stander without training in the safe operation of standers and slings. **IF IN DOUBT DO NOT USE** .

DO NOT use the stander where any doubt exists regarding the safety of the stander including but not limited to wear or damage with particular importance to be placed on the yoke and sling attachment points.

DO NOT use the stander with slings showing any signs of wear or damage, including fraying.

DO NOT exceed the 200kg safe working load of the ASPIRE 200S Stander.

DO NOT use the stander as a means of transportation over distances in excess of 3 metres. It is not designed as a transportation device.



INTENDED USE OF THE PRODUCT

WARNING: DO NOT manually lift the boom of the lifters.

How to Use Correctly:

The boom of the lifter is designed to be lifted only by an electric actuator.

Aidacare Lifters and Stenders do not pull downwards during lowering. This safety spline feature is designed to avoid entrapment and crush injuries.

This safety feature means that it is physically possible to raise the lifter boom by hand on some models with LA31 actuators fitted.

NEVER raise the lifter boom by hand or any other means except under direct drive from the electric actuator fitted to the lifter.

Raising the boom can cause it to become stuck in an elevated position. Under load this can result in patient free fall and risk catastrophic injury to the patient and/or carer.

ALWAYS use the handset or control unit buttons to raise and lower the boom of the lifter. This will ensure correct and safe functioning at all times.

3. PARTS GLOSSARY



1	Boom
2	Sling Bar / Yoke
3	Lift Actuator
4	Mast
5	Battery
6	Cover for Leg Actuator
7	Leg Spread Actuator
8	Handset
9	Push Handle
10	Adjustable Knee Pads
11	Rear Castors with Brake
12	Foot Platform
13	Front Castors
14	Base Fastening Lever
15	Emergency Lowering Function
16	Emergency Stop Button

4. ASSEMBLY

1. Unpack

Remove all parts from carton.



2. Attach the mast

Insert the mast into the base, ensuring the holes align and secure with base fastening lever bolt.

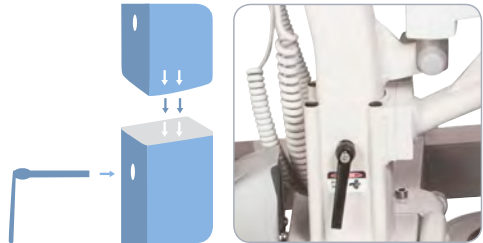

3. Mount handle

Mount push handle onto mast in position shown and fasten screws with Allen key.



4. Attach the knee pads

Position the knee pads onto the mount point located toward the base of the lifter. Attach with four fixing bolts (supplied)

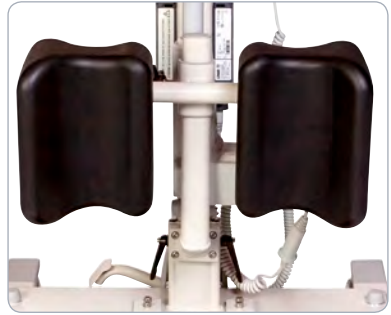

5. Connecting the actuator

a) Connect grey actuator lead into port (1) located on base of the control unit.

b) Connect the other end into the female lead from the actuator.



6. Connecting the handset

Connect grey handset lead into port located on base of control unit.



7. Connecting the Leg Spread Actuator

Connect black actuator lead port (2) on base of control unit.



5. PRELIMINARY CHECKS

After charging the battery these checks should be completed prior to initially using the stander:

1. Check handset functionality is correct.
2. Check to see that all indicator lights are functioning.
3. Check that the emergency stop button causes the stander to stop.
4. Check emergency lowering function.
5. Check that all leads are inserted, fastened and clear of the rear castors.

6. STANDER OPERATION

Handset

Features:

1. Raise / Lower Function Buttons

Press to move the lifter up and down. Release to stop movement. Always ensure the environment is free of obstacles that may impede movement.

2. Leg Spread Function Buttons

Press to open and close the lifter's legs. Release to stop movement. This allows you to fit the lifter around furniture, such as chairs. Always ensure the environment is free of obstacles that may impede movement.

3. Battery Charge Indicators

Battery charge indicators will flash when battery reaches maximum recommended discharge of 18 volts, while the lifter is under load.

4. Service Indicator

This will illuminate to show that a service is required. This is usually after 12 months or 8,000 lift cycles - whichever comes first. You do not have to stop using your lifter when this illuminates, simply contact your Aspire dealer to arrange a service.



- Press and hold the raise / lower or leg spread (if applicable) function buttons to activate. Release to deactivate. Beware of obstacles at all times to ensure boom and legs can move freely.
- Battery charge indicators will flash when battery reaches maximum recommended discharge of 18 volts, while the lifter is under load.
- Service indicator will illuminate when lifter has reached recommended service interval, either 12 months since last service or 8000 lift cycles. At this time the lifter needs to be serviced for safety and to maintain applicable warranty.

A full load test should be completed at least every 12 months by an Aidacare service technician.

Emergency Lowering

To activate emergency lowering lift up red tab located on top of actuator.

This allows the patient to be fully lowered in the event of a fault in the lifter or discharged batteries.



Kneepad Adjustment

Using the kneepad height adjuster, set the kneepads at the desired height. Using the kneepad width adjuster, set the distance between the pads for desired width.

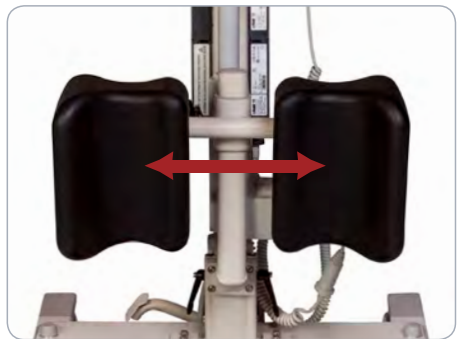

6. STANDER OPERATION CONT.

Charging the battery

The ASPIRE 200S Stander is supplied with a LINAK external wall mount charger and is compatible with standard Australian power outlets.

The following steps should be completed to recharge the battery pack correctly:

- a) Remove the battery pack from the stander via the top mounted release lever.
- b) Connect the battery pack to the charger.
- c) Charger will automatically activate the charging sequence and a light will illuminate to show charging has commenced.



CHARGING INDICATOR DISPLAY

GREEN LIGHT indicates mains power is connected to 240 v power supply.

ORANGE LIGHT indicates battery is charging, and will turn off automatically when battery is fully charged.



- d) When fully charged, place the battery back onto the lifter, ensuring that you hear a click. This indicates the battery is sitting correctly in the lifter.

Charging Dos & Don'ts:

ALWAYS

- Charge the battery whenever possible, to maximize battery life. Allowing batteries to fully discharge can reduce the useful life of a battery.
- Always inspect all cables particularly the mains power cable on the charger for any damage; replace if any signs of damage or wear are visible.
- Always stow the handset, charger and mains power cable when transporting the stander to prevent loss and or damage.
- Always clean the actuators, control box, charger, battery and handset at regular intervals to remove dust/dirt.

NEVER

- Never allow the battery to fully discharge before recharging. Allowing batteries to fully discharge can reduce the useful life of a battery.

Castors

To **engage the castor brakes** place your foot on the brake pedal and apply sufficient downward force to move it into the lock position.



To **disengage the castor brake** simply place the point of your toe underneath the brake pedal and lift-up.



Emergency Stop

To **engage the emergency stop** press the red button located on the control unit until it sits flush and remains in position.



To **disengage** the emergency stop function twist the red button clockwise until it pops out



7. STANDING GUIDE

It is important that carers are familiar with manual handling techniques along with any sling instructions prior to completing any patient lifts. All patients should have the correct sling and transfer techniques assessed by a qualified health professional. Explaining the lift process to the patient is important to ensure patient comfort and confidence and whenever possible two carers should conduct patient lifts for additional safety.

1. Patient sling positioning

Ensure that the patient is ready and lean them forward. Slide the sling down behind the patient until the underarm pads are just below the axilla (arm pit). Pull the straps and loops through under the patient's arms and fasten the chest strap in place.

2. Attaching the sling to the yoke

Ensure that the stander legs are open to the maximum width and slowly position it as close to the front of the chair as possible – be careful to keep the boom and yoke clear of the patient during this process.

The patient's feet should be positioned on the foot platform shoulder width apart. The patient should grip the handles on the sling bar for stability.

Once the yoke is at chest height on the patient the sling loops can be attached. For chair lifts the rear brake castors should not be used to ensure the stander can locate its centre of gravity easily.

3. Lifting the patient

Raise the yoke until the loops of the sling pull tight. Check that the patient is still comfortable and that the sling is correctly positioned. Ask the patient to lean back into the sling and straighten their legs as the lifter rises. Raise the patient slowly until the patient is in a standing position.



8. SLING COMPATIBILITY

The Deluxe Padded Standing Sling has been developed to work seamlessly with the Aidacare range of standing lifters.

This stander may also be suitable for use with other brands of slings. To confirm if a sling is compatible with any of the ASPIRE range of patient lifting systems contact AIDACARE on 1300 133 120.



Deluxe Padded Standing Sling

9. CARE & MAINTENANCE

To prolong the working life of the stander and for trouble free operation it is recommended that periodic inspections should be performed routinely by a person who is suitably qualified and well acquainted with the design, use and care of patient standers.

If inspection reveals that the safety of the stander is jeopardized in any way the stander should be IMMEDIATELY WITHDRAWN FROM SERVICE, tagged as such and the owner notified.

MAINTENANCE GUIDE & CHECK LIST

- Check castors are fastened securely to the frame
- Castors should run and swivel smoothly - if hair or other fibres have built up within the castor this should be removed
- Check that the brakes on the rear castors function normally
- Clean surfaces with a pH neutral detergent - chlorine and phenol based detergents should not be used as these may damage stander components
- All moving parts and pivot points should be checked for fatigue and lubricated if necessary
- All electrical components should be checked for normal function including battery and battery charger
- The actuator shaft should only be wiped with a cloth. DO NOT lubricate, contact Aidacare maintenance 1300 133 120.

AS A MINIMUM A FULL SERVICE SHOULD BE COMPLETED EVERY 6 MONTHS AND THE LOAD TEST EVERY 12 MONTHS TO MAINTAIN WARRANTY.

ELECTRICAL TEST & TAG - WHERE LIFTERS ARE IN USE IN A COMMERCIAL ENVIRONMENT THEN THE TESTING REGIME APPLIED SHOULD ALIGN WITH THE RISK ASSESSMENT MADE BY THE OWNER FOR SAFETY AND OTHER COMPLIANCE REQUIREMENTS.

TO MAINTAIN AUSTRALIAN STANDARDS COMPLIANCE UNDER AS ISO 10535-2011 A FULL SWL TEST MUST BE COMPLETED EVERY 12 MONTHS.

10. WARRANTY & SERVICE

STANDER AND ELECTRONICS

AIDACARE warrants its products to be free from defects in materials and workmanship under normal use and service and will within the period stated below, from the date of purchase, repair or replace without cost to the original customer, any part assembly or portion thereof which shall be returned to AIDACARE and from OUR inspection shows to be defective.

1. Patient Stander Frame – 5 years
2. LINAK Actuator and LINAK Controller – 3 years (excluding Battery Pack)
3. LINAK Battery Pack – 12 month manufacturer’s warranty subject to stringent fair wear and tear clauses (please contact AIDACARE for a copy of this information)

WARRANTY IS CONTINGENT UPON ANNUAL SERVICING BEING COMPLETED FOR THE LENGTH OF THE WARRANTY PERIOD.

AIDACARE cannot be held responsible for any personal injury, damage to the stander or damage to property as a result of the improper or unsafe use of the product.

No warranty claim shall apply where the product or any part thereof has been modified, varied, altered or damaged either accidentally or through improper or negligent use.

No warranty claim shall apply where the stander is repaired or serviced by parties other than those accredited and or approved by Aidacare.

Warranty does not extend to items or components which may require replacement due to normal wear and tear (e.g. castors, plastic molded components, foam padding (where fitted) and painted surfaces) for which AIDACARE nor its distributors can be held responsible.

BATTERIES

Batteries carry a limited warranty from the original manufacturer which is subject to a stringent wear and tear clause. Battery faults due to defect in original manufacture typically become apparent within the first two months of use.

Any gradual deterioration in performance after this period is typically associated with fair wear and tear, misuse and accidental damage, and as such is not covered by the LINAK manufacturer’s warranty.

ALL WARRANTIES MADE ARE BACK TO BASE WARRANTIES MEANING THAT ANY PARTS OR WHOLE STANDERS REQUIRING REPAIR NEED TO BE RETURNED TO THE NEAREST AIDACARE SERVICE CENTRE AT THE CUSTOMER’S EXPENSE – PLEASE CONTACT AIDACARE FOR A CURRENT LIST OF SERVICE CENTRE LOCATIONS.

11. TROUBLESHOOTING

WARNING: TROUBLESHOOTING SHOULD ONLY BE CARRIED OUT BY AIDACARE AUTHORISED SERVICE TECHNICIANS WHO ARE TRAINED IN SERVICING THE ELECTRICAL AND MECHANICAL FEATURES OF THE PATIENT STANDER.

The following is a guideline only to general troubleshooting.

Before carrying out any troubleshooting:

- CHECK TO ENSURE the RED emergency stop button is NOT pushed in.
- CHECK TO ENSURE maintenance procedures have been followed.
- CHECK TO ENSURE all lead connections are secure.
- CHECK TO ENSURE the battery is fully charged.

PROBLEM	POTENTIAL FAULT	ACTION
Warning alarm can be heard in control unit	Battery is discharged Battery may be faulty	Recharge battery Replace battery
Power LED on charger does not illuminate	Not connected to power Fuse blown Faulty Charger	Check plugged in to power point and switched on Replace fuse Repair or replace charger
Actuator not running/no click heard from control unit when buttons pressed	Faulty control unit Faulty handset	Repair or replace control unit
Actuator not running but control unit clocks when buttons pressed	Actuator plug not inserted fully into control unit Faulty actuator Faulty control unit	Check plugs are completely inserted into control unit ports Repair or replace actuator and or control unit
Actuator not lifting properly or running slowly	Discharged or faulty battery Weight in excess of safe working load (SWL) Faulty actuator	Recharge or replace battery Repair or replace actuator
No clicking in control box when buttons pressed	Emergency stop button pressed Battery completely discharged Battery fuse faulty Faulty control unit	Release emergency stop button Recharge battery Repair or replace control unit
Actuator only works in one direction	Faulty handset Faulty control unit Emergency lower release activated	Repair or replace handset Repair or replace control unit Check emergency actuator release is reset

12. SPECIFICATIONS

Product Code	LSS390650
Safe Working Load (SWL)	200kg
Base Length	1150mm
External Base Width	655-1016mm
Internal Base Width	575-936mm
Base Width Adjustment	Electric
Base Height / Under Bed Clearance	110mm
Minimum Height of Spreader Bar	850mm
Maximum Height of Spreader Bar	1740mm
Stander Weight	44.9kg
Warranty	Frame: 5 Years Electronics: 3 Years Battery Pack: 1 Year
Under Base Height	50mm
Maximum Overall Height	1790mm
Front Castor Diameter	75mm
Rear Locking Castor Diameter	100mm
Turning Diameter	1255mm
Weight Of Heaviest Part (Base Assembly)	25.1kg
Handle Height	1030mm
Sound Level	<40Db@ 1m
Electrical Approval	EN 60601-1-2:2007; EN 61000-3-2:2006; EN 6100-3-3:2008

Box Contains: Base with 4 castor wheels, mast and boom with yoke, LINAK handset, LINAK battery charger, LINAK battery, LINAK controller, push handle. Screws, bolts, nuts, washers, plastic caps and tool kit.

12. SPECIFICATIONS (CONT.)

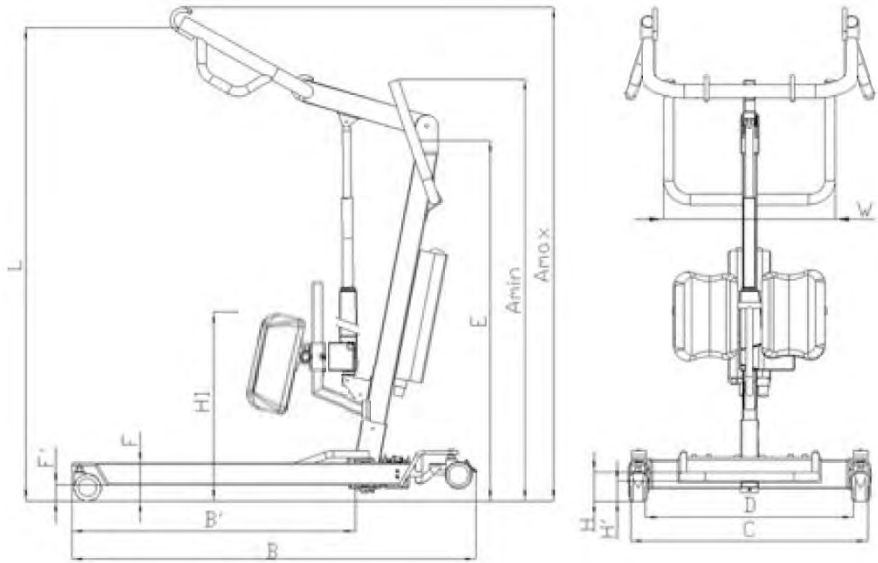

Max. load	L		A		B	B'	C	D	E	F	F'	H	H'	H1	W	NW	Turning diameter
	Max.	Min.	Max.	Min.													
200	174	85	179.0	117	115	79	65.5-101.6 (Tolerance +/2cm)	67.5-93.6 (Tolerance +/2cm)	103	11	5	10.5	6.5	58.5	48	41	125.5

13. SERVICE LOG BOOK

YEAR 1

Date: _____

Service Type: _____

Condition Report: _____

Inspected by: _____ Signature: _____

Action taken: _____

_____ Date: _____

YEAR 2

Date: _____

Service Type: _____

Condition Report: _____

Inspected by: _____ Signature: _____

Action taken: _____

_____ Date: _____

YEAR 3

Date: _____

Service Type: _____

Condition Report: _____

Inspected by: _____ Signature: _____

Action taken: _____

_____ Date: _____

YEAR 4

Date: _____

Service Type: _____

Condition Report: _____

Inspected by: _____ Signature: _____

Action taken: _____

_____ Date: _____

YEAR 5

Date: _____

Service Type: _____

Condition Report: _____

Inspected by: _____ Signature: _____

Action taken: _____

_____ Date: _____

SPARE PARTS

SPARE PARTS LIST AVAILABLE UPON REQUEST FROM AIDACARE ON
1300 130 122 or www.aidacarelifters.com.au

Associated Range Overviews



Aidacare Sling Auditing

Old Slings? Don't risk it.
An old, worn out or faulty sling could be a significant safety risk for your organisation

Aidacare's Sling Audit Program can assist you to ensure your sling inventory is in safe working order at all times.

Periodic sling audits are now a mandatory accreditation requirement. Ask us how we can help you manage the risk in this area of your business.

1300 133 120
www.aidacare.com.au



AIDACARE PTY LTD

Building 3A, 1 Moorebank Avenue,
Moorebank NSW 2170

1300 133 120

www.aidacare.com.au

MADE IN CHINA