



CombiMotion

USER MANUAL

MODELS INCLUDE:

LUXE ADJUSTABLE BED

CARE ADJUSTABLE BED

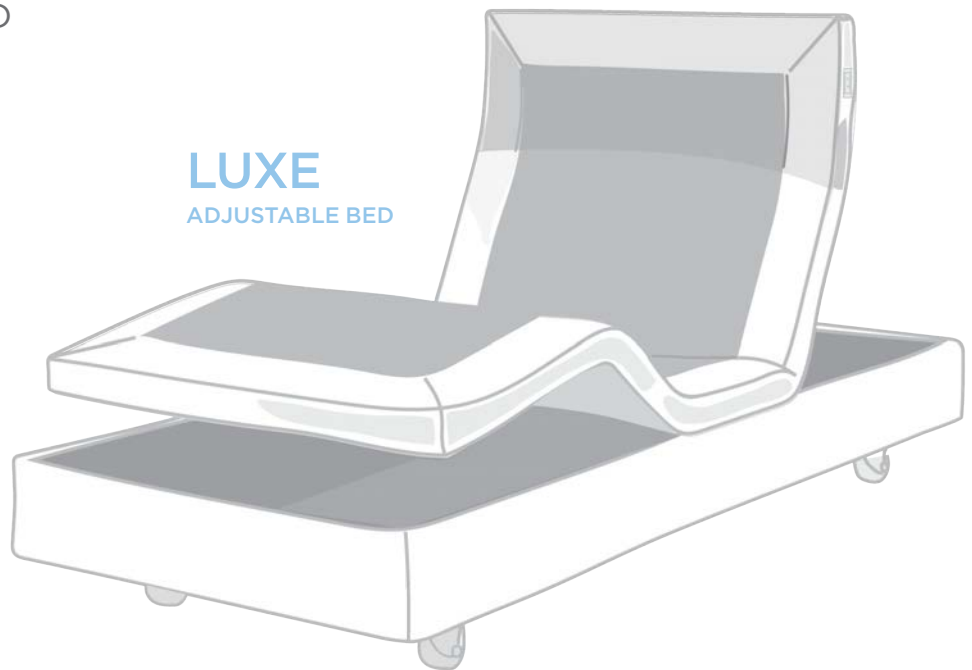

Thank you for choosing this Aspire ComfiMotion Adjustable Bed.

Our ComfiMotion Collection is designed to blend seamlessly into the home environment, whilst improving comfort and independence.

It is important that you read this user manual carefully before using your new Adjustable bed.

TABLE OF CONTENTS

1.	Symbols Used In This Manual	4
2.	Introduction	5
3.	Safety Precautions	6
4.	Specifications & Inclusions	8
	4.1 LUXE Adjustable Bed	
	4.2 CARE Adjustable Bed	
5.	Accessories	10
6.	Handset Operation	11
	6.1 LUXE Bed - Wireless Handset	
	6.2 CARE Bed - Wired Handset	
7.	Assembly Instructions	14
	7.1 BEDS - How to Unpack & Install	
	7.1.1 LEG TYPE - How to Fit	
	7.2 HEADBOARDS - How to Assemble or Mount	
	7.2.1 Option 1: Assemble Freestanding	
	7.1.1 Option 2: Mounted to Bed	
	7.3 ACCESSORIES - How to Fit to Bed	
8.	Storage & Movement	25
9.	Cleaning	26
10.	Service & Maintenance	27
11.	Troubleshooting	28
12.	Warranty & Service	29
13.	Service Log Book	30

SYMBOLS USED IN THIS MANUAL

The symbols below are used throughout this owner's manual and on the product to identify warnings and important information. It is very important for you to read them and understand them completely.



WARNING

WARNING! Indicates a potentially hazardous condition/situation. Failure to follow designated procedures can cause either personal injury, component damage or malfunction. On the product, this icon is represented as a black symbol on a white triangle with a black border.



ALWAYS! These actions should be performed as specified. Failure to perform mandatory actions can cause personal injury and/or equipment damage. On the product, this icon is represented as a white infinity symbol on a black dot with a white border.



DO NOT! These actions are prohibited. These actions should not be performed at any time or in any circumstances. Performing a prohibited action can cause personal injury and/or equipment damage. On the product, this icon is represented as a white symbol with a black circle and black slash.



MAX USER WEIGHT
150 KG

MAXIMUM PATIENT WEIGHT.

This weight represents the total maximum weight of a patient on the bed. This weight (150kg) should not be exceeded at any time.



SWL FOR BED
180 KG

SAFE WORKING LOAD (SWL).

This weight represents the total maximum weight that the bed can carry, including patient, mattress, bedding, bed ends and accessories. This weight (180kg) should not be exceeded at any time.

1. INTRODUCTION

Aspire ComfiMotion Adjustable Beds are equipped with functions and features, engineered to enhance user comfort, independence and safety. Designed for easy, multi-positional operation, cleaning and serviceability, this luxurious adjustable bed collection uses premium quality materials and finishes.



KEY FEATURES

Maximum safe working load (SWL) of the beds is 180kg with a suggested maximum user weight of 150kg which conservatively takes into account common accessories such as alternating pressure mattresses, assist bars and foam mattresses.

- **Night Assist:** Luminous underbed halo for safe entry and exit throughout the night.
- **Box-on-Box Design** facilitates easier entry and exit and allows true flush positioning of beds in companion or dual adjustable bed configurations.
- **German Engineered Motors** for smooth, quiet adjustment.
- **Massage:** Relaxing vibration modes for personalised neck, shoulder and back relief (**LUXE Bed Only**).
- **USB Charge:** Connect and charge your devices conveniently (**LUXE Bed Only**).
- **Press and Hold Safety Handset:** Intuitive, large button interface enhances usability.
- **Enclosed Frame Design:** Ensures optimal positioning when getting into bed and safely covers the moving base platform.
- **Safe-Lowering Technology:** Ensures that back, leg and Hi-Lo functions only lower under the force of gravity reducing potential for accidents or injuries.

2. SAFETY PRECAUTIONS

This User Manual outlines the intended use of an Aspire ComfiMotion Adjustable Bed. This constitutes how to achieve full functionality, whilst maximising the safety and efficiency of carers and users alike.

It is **important** that this User Manual is read in its entirety, prior to operating the bed. The manual is designed to ensure that users are equipped with all the information required to competently and responsibly operate the bed and its accessories.

It is recommended that the User Manual be kept in an easily accessible place for quick reference. If required Aidacare product specialists can provide additional training.

All warnings and cautions within this manual should be strictly adhered to. Failure to do so could result in harm to the carer or user.

Warnings highlighted throughout this manual identify possible hazards in procedures or conditions which if not followed correctly could result in serious injury, or fatality.

Cautions highlighted throughout this manual identify possible hazards in procedures or conditions, which if not followed correctly could result in equipment damage, or failure.

GENERAL

- Electrical equipment can be hazardous if used incorrectly.
- The clinically qualified person responsible should consider the age, size and condition of the patient before using the bed and its accessories.
- The maximum safe working load of the Bed is 180kg and includes the mass of the patient, mattress and any accessories fitted to the bed.
- The maximum suggested standard mattress thickness for use with ComfiMotion Beds is 240mm.
- The bed should only be used with approved accessories. Contact Aidacare for a full list of approved accessories.
- If a patient's condition could lead to a possible entrapment the mattress support platform should be left in the flat position whilst unattended.

 **ALWAYS** position the bed at its lowest height when unattended to minimise the risk of patient injury from falls when getting in and out of the bed.

 **ALWAYS** use a mattress of appropriate size and type. A range of suitable mattresses are also available from Aidacare.

 **ALWAYS** make sure that the user is safely positioned to avoid entrapment before operating the bed.

 **ALWAYS** ensure that carer and user limbs are free from potential entrapment areas before operating any functions.

 **ALWAYS** apply the brakes (if castors installed) when the bed is stationary.

 **ALWAYS** store the handset when not in use to avoid accidental operation of the bed's functions.

 **DO NOT** use electrically operated beds in the presence of flammable gases.

 **DO NOT** use accessories that are not designed, or approved for use with ComfiMotion Beds.

3. SPECIFICATIONS & INCLUSIONS

3.1 LUXE ADJUSTABLE BED

Please ensure you have familiarised yourself with the critical information below.

STANDARD LUXE INCLUSIONS:

- x5** **MATTRESS RETAINERS**
4x Small (Side).
1x Long (Footend of Bed).
- x1** **WIRELESS HANDSET**
See "Handset Operation" for usability instructions.
- NIGHT ASSIST**
Underbed lighting.
- x4** **LOW-PROFILE FIXED LEGS**
Kit available upon request.
- x4** **75MM CASTORS**
(Optional 125mm Accessibility castors are required for patient lifter or overbed table access).

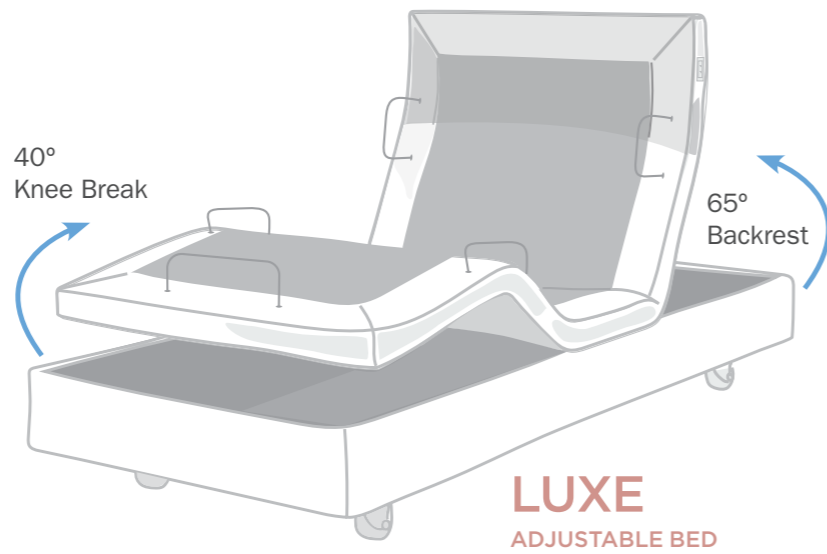

LUXE	OVERALL LENGTH X WIDTH	HEIGHT RANGE (DIFFERENT LEG OPTIONS)		RECOMMENDED MATTRESS SIZE (LxWxH)
		Low-Profile Fixed Legs	75mm (Standard) Castors	
KING SINGLE BEB046710	2030 x 1070mm	280 - 580mm	350 - 650mm	King Single 2030 x 1070 x 200 - 240mm
		350 - 650mm	400 - 700mm	
		400 - 700mm		

KS BED WEIGHS
100 KG

MAX USER WEIGHT
150 KG

SWL FOR BED
180 KG

*Increases underbed clearance to accommodate most patient lifters.

3.2 CARE ADJUSTABLE BED

Please ensure you have familiarised yourself with the critical information below.

STANDARD CARE INCLUSIONS:

- x5** **MATTRESS RETAINERS**
4x Small (Side).
1x Long (Footend of Bed).
- x1** **HANDSET**
See "Handset Operation" for usability instructions.
- NIGHT ASSIST**
Underbed lighting.
- x4** **LOW-PROFILE FIXED LEGS**
Kit available upon request.
- x4** **75MM CASTORS**
(Optional 125mm Accessibility castors are required for patient lifter or overbed table access).

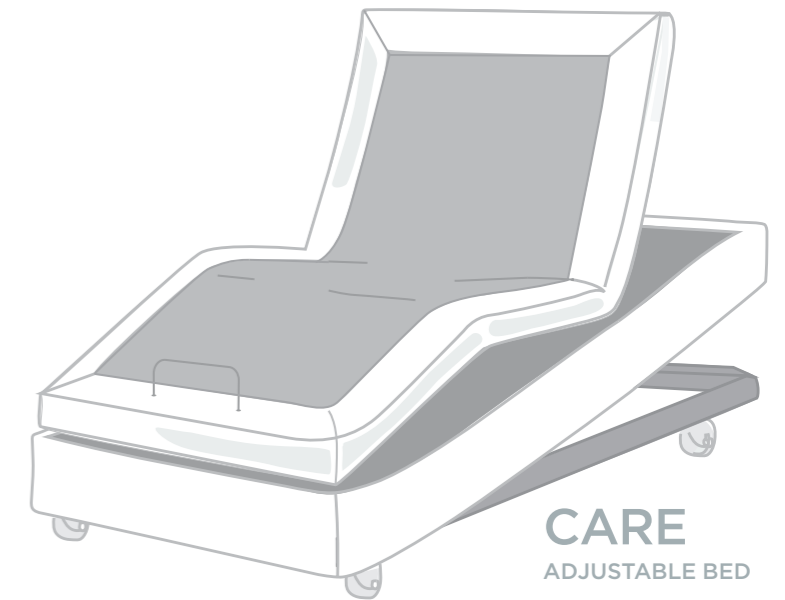

CARE	OVERALL LENGTH X WIDTH	HEIGHT RANGE (DIFFERENT LEG OPTIONS)		RECOMMENDED MATTRESS SIZE (LxWxH)
		Low-Profile Fixed Legs	75mm (Standard) Castors	
LONG SINGLE BEB046720	2030 x 920mm	280 - 580mm	350 - 650mm	Long Single 2030 x 920 x 200 - 240mm
		350 - 650mm	400 - 700mm	
		400 - 700mm		
KING SINGLE BEB046730	2030 x 1070mm	280 - 580mm	350 - 650mm	King Single 2030 x 1070 x 200 - 240mm
		350 - 650mm	400 - 700mm	
		400 - 700mm		

LS BED WEIGHS
90 KG

KS BED WEIGHS
100 KG







MAX USER WEIGHT
150 KG

SWL FOR BED
180 KG

*Increases underbed clearance to accommodate most patient lifters.

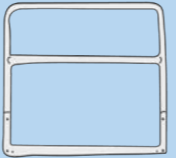
5. ACCESSORIES

A range of ComfiMotion Bed accessories are available. In addition to the below listed accessories, Aidacare specialises in other complimentary products such as foam mattresses, pressure care surfaces, over bed tables, side lockers and adjustable day chairs. Please contact Customer Service on 1300 133 120 for further information.

CODE	DESCRIPTION	IMAGE
LONG SINGLE BEA830120 KING SINGLE BEA830130	Allure Headboard	
LONG SINGLE BEA830100 KING SINGLE BEA830110	Chesterfield Headboard	
BEA830200	Crook Handle Bed Stick	
BEA830210	Bed Rail	
MWT451080 (4 X REQUIRED)	Larger Castors	
BEA830220	Battery Back Up	
BEA824200	Aspire ComfiMotion Transport Trolley	



Do not use accessories that have not been designed for use with ComfiMotion Beds.

6. HANDSET OPERATION

PLEASE READ THE CRITICAL INFORMATION BELOW:



- Ensure the user, carer and/or equipment is positioned to avoid being trapped or crushed during bed adjustment.
- Ensure the handset cord is not stretched excessively (**CARE Bed Only**).
- Ensure the handset and electrical leads cannot become entangled with moving parts of the bed.
- DISCONNECT the power lead from the mains and stow before transporting the bed.
- If the power lead shows any sign of damage, replace immediately.

UNDERSTANDING THE RELEVANT HANDSET

ComfiMotion Beds are powered by four electric actuators, which are controlled by the Handset. Adjustment occurs only while a button is pressed. Adjustment will stop when the button is released, or the selection reaches the end of its range.

LUXE BED WIRELESS

Handset requires pairing via sync



CARE BED WIRED

Handset requires simple cord setup

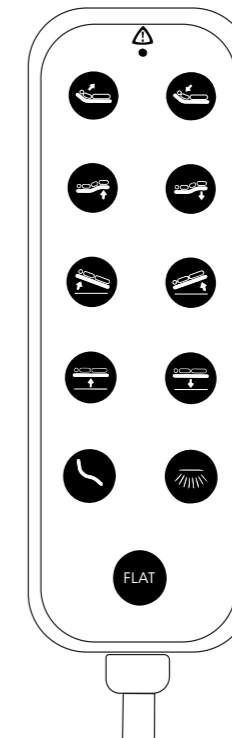

IMPORTANT INFO - (LUXE & CARE)



Extra care should be taken whilst operating the bed functions to ensure hands and fingers are free from potential squeeze hazards.

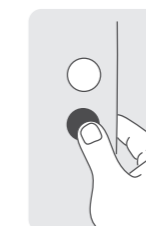

USING YOUR HANDSET

PRESS & HOLD to initiate function
RELEASE button to stop

6.1 LUXE BED - WIRELESS HANDSET

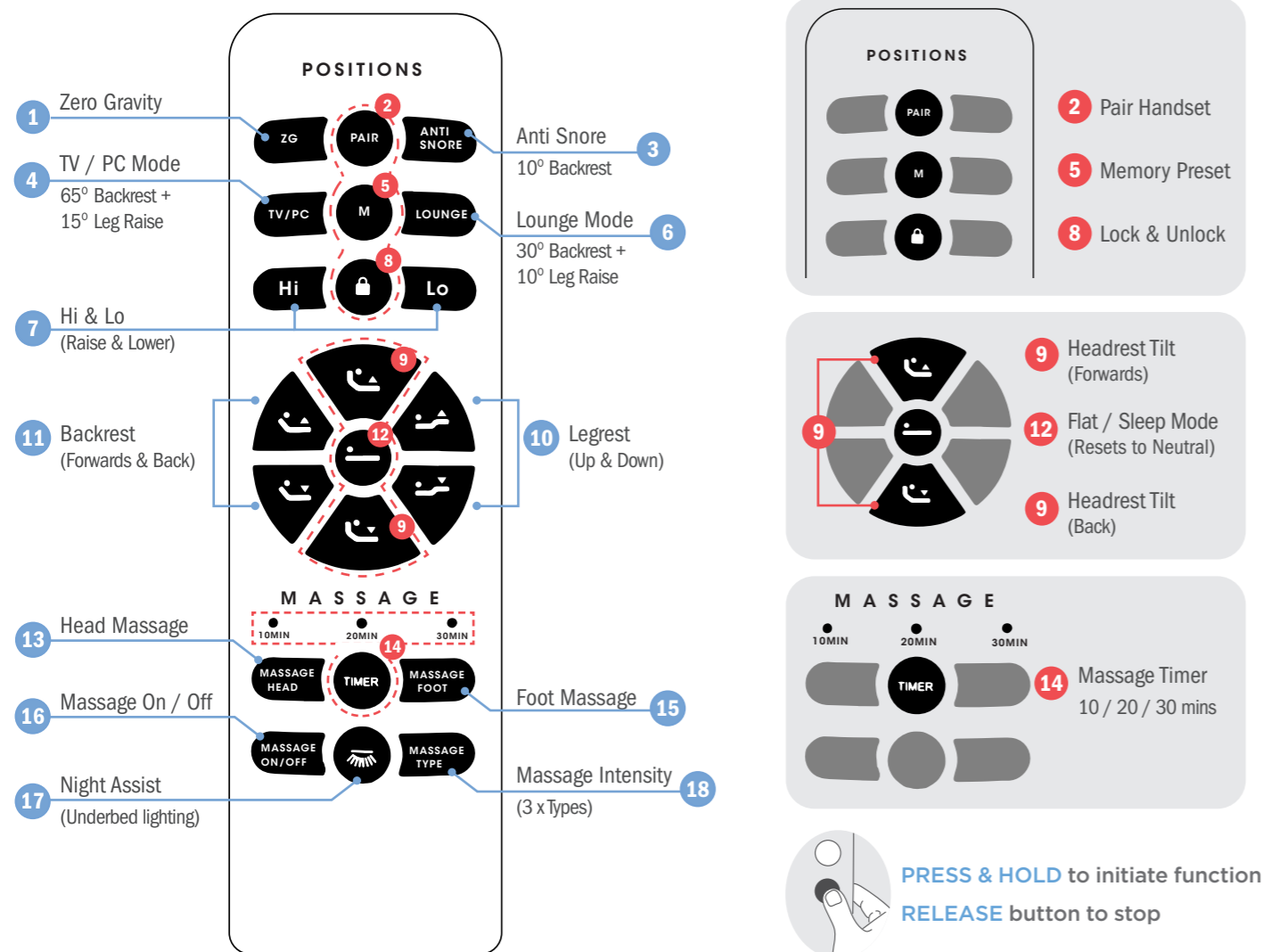

- 1. Zero Gravity:** Simultaneously raises the backrest by 20° and legrest (also known as knee-break) to a 40° angle. This position helps to relax the circulatory system and muscles of the lower back, creating a sense of weightlessness.
- 2. Pair*:** Handsets come pre-paired in the box however if you replace your handset, see below instructions on how to pair your new handset to your bed:
On the control box, double click the 'PAIR' button until the LED illuminates.
On the handset, press and hold the button until the 'BLUE' LED changes to 'GREEN'.
NOTE: If this does not occur within 10secs, repeat above steps.
- 3. Anti-Snore:** Slight elevation of backrest (10°) to help ease symptoms of respiratory conditions, when sleeping.
- 4. TV/PC Mode:** Simultaneously raises the backrest (65°) and legrest (15°), ideal for watching TV or using smart devices.
- 5. Memory Preset:** Nominate and adjust to the preferred position (x1 PRESET ONLY). Then, hold the 'M' button down until the underbed light flashes. This will now be stored as a preset, when 'M' is selected.
- 6. Lounge Mode:** Simultaneously raises the backrest (30°) and legrest (40°) to maximise comfort and relaxation.
- 7. Hi / Lo:** Raise and lowers the height of the bed. Consider lowering the bed to assist with bed entry and exit.
- 8. Lock & Unlock:** To **LOCK** all functions, "PRESS & HOLD" until button flashes red. To **UNLOCK**, "PRESS & HOLD" for 5secs.
- 9. Headrest Tilt:** Adjusts the headrest between 65 - 85°. This can help alleviate neck muscle strain, providing optimal support while reading or watching TV.
- 10. Legrest:** Adjust the legrest to promote better circulation, relieving tired, swollen and/or painful limbs.
- 11. Backrest:** Adjusts the backrest (up to 65°) providing postural support, easing symptoms of reflux, respiratory conditions, snoring and sleep apnoea.
- 12. Flat / Sleep Mode:** Resets to a neutral flat position, simultaneously lowering the bed to the minimum height.
- 13. Head Massage:** Activates the headrest massage function.
- 14. Massage Timer:** Allows users to nominate how long they will the massage to operate for at 10, 20 or 30min intervals.
- 15. Foot Massage:** Activates the foot section massage function.
- 16. Massage On / Off:** Switches the massage function 'ON' and 'OFF'. **NOTE:** Message ON/OFF must be pressed prior to using any of the massage functions.
- 17. Night Assist:** Luminous underbed halo (lighting) for safe bed entry and exit throughout the night.
- 18. Massage Intensity:** Choose between three different types of massage intensities.

*NOTE: If handset unpairs from the bed at any stage, please refer to 'PAIR' instructions above.

6.2 CARE BED - WIRED HANDSET



6.2.1 SETTING UP YOUR CARE HANDSET

To connect the handset: Insert and secure the handset cable into the port labelled 'HANDSET' (located in the control box underneath the bed).

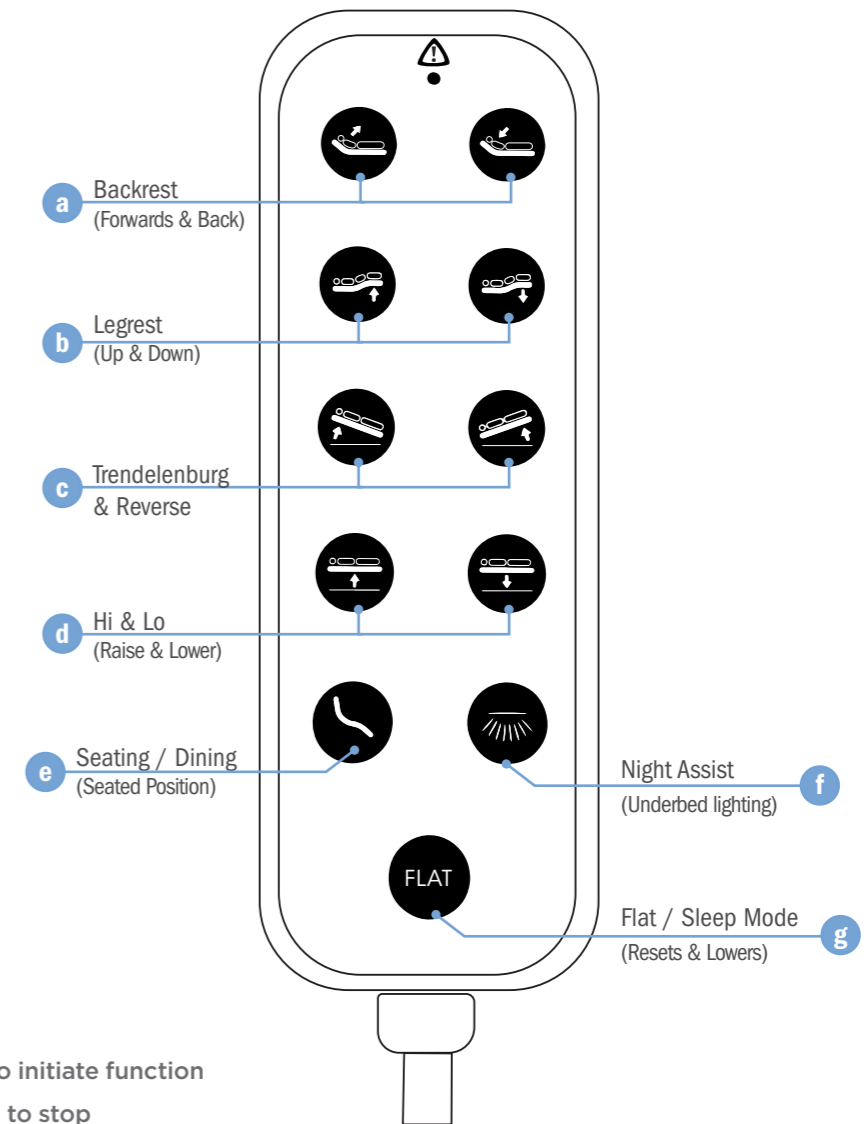

PRESS & HOLD to initiate function
RELEASE button to stop

- a. Backrest:** Adjusts the backrest (up to 65°) providing postural support, easing symptoms of reflux, respiratory conditions, snoring and sleep apnoea.
- b. Legrest:** Adjust the legrest to promote better circulation, relieving tired, swollen and/or painful limbs.
- c. Trendelenburg (-12°) and Reverse (12°):** This position helps facilitate blood pressure localisation as well as promote low cardiac output. This medically prescribed position is not recommended for those with heart issues or those susceptible to strokes.
- d. Hi / Lo:** Raise and lowers the height of the bed. Consider lowering the bed to assist with manual handling and help mitigate falls risk.
- e. Seating and Dining:** Bed transforms into a seated position, ideal for upright dining as well as bed entry and exit.
- f. Night Assist:** Luminous underbed halo (lighting) for safe bed entry and exit throughout the night.
- g. Flat / Sleep Mode:** Resets to a neutral flat position, simultaneously lowering the bed to the minimum height.

7. ASSEMBLY INSTRUCTIONS

GETTING STARTED

ComfiMotion Beds come securely packaged in a cardboard carton. Inside the carton you will find the castors, retainers and hand control safely secured underneath the bed frame. The entire bed is also wrapped for further protection. ComfiMotion Beds should arrive to you in pristine condition, ready for immediate assembly and installation.

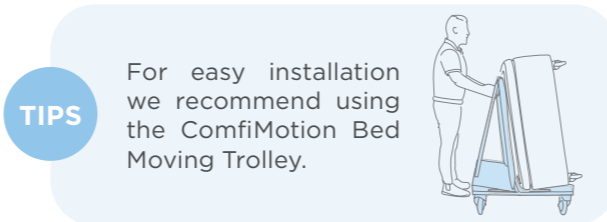

Carton Contents:

- 1 x ComfiMotion Bed (CARE or LUXE)
- 1 x Handset
- 1 x Headboard (Sold Separately)
- 4 x 75mm Locking Castors
- 4 x Low Profile Bed Legs (or available upon request)
- 4 x Side Mattress Retainers and Hardware
- 1 x Foot End Mattress Retainer



ComfiMotion Beds are a large piece of equipment requiring special attention and careful handling at all times.



When opening the carton, ensure it is done in a safe and careful manner. **DO NOT USE** a box cutter or sharp implement down the centre of the carton as this may damage the product.

7.1 BEDS

HOW TO UNPACK & INSTALL LUXE / CARE BEDS

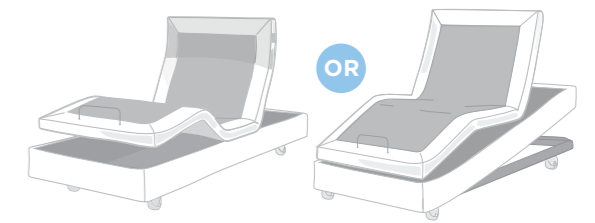

ADJUSTABLE BEDS	LUXE (KS) BEB046710	CARE (LS) BEB046720	CARE (KS) BEB046730
-----------------	---------------------	---------------------	---------------------

- 1 Remove bed from carton and position on flat surface or a Bed Moving Trolley for easy setup. Ensure the bed is placed TOP DOWN, so all components (hand control, retainers, castors & power cord) can be removed easily from the underside of bed.



DO NOT USE a box cutter, stanley knife or sharp implement when opening the carton.

Doing so may cause irreversible damage to the product and void warranty.

- 2 Using a box cutter, unhook all components from the base of the bed (retainers, power cord, hand control and castors).

Retainers



Hand Control



Castors



Power Cord



7.1.1 LEG TYPE

HOW TO FIT LEGS / CASTORS

SELECT PREFERRED
BED HEIGHT:



280 - 580mm with
Low Profile Bed Legs

OR



350 - 650mm with
Standard Castors

OR

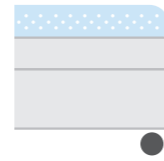

400 - 700mm with
Accessibility Castors

3 **IMPORTANT!** The leg or castor selection (a, b, or c) will determine the minimum bed base height (not including the mattress). Please refer to the different leg options above for their specific height ranges.

IMPORTANT! Beds should remain on their side when installing the legs or castors.



2 X PEOPLE REQUIRED: We strongly recommend having an additional person to hold the bed frame whilst installing the legs or castors to avoid tipping.

WARNING



a) Low Profile Bed Legs

- Insert the protruding stem into the hole located at each corner of the bed.
- Fasten by hand and tighten with spanner. Repeat for each leg.



b) Standard Castors

- Insert the protruding castor stem into the hole located at each corner of the bed.
- Fasten by hand and tighten with spanner. Repeat for each castor.



c) Accessibility Castors

- Insert the protruding castor stem into the hole located at each corner of the bed.



- Fasten using an 8mm Allen Key. Repeat for each castor.



4 Connect hand control into control box port (**CARE bed only**).



NOTE: LUXE Bed has a wireless Hand Control, no need to connect to Control Box.

5 Cut safety securing straps that hold the bed in place when in carton.

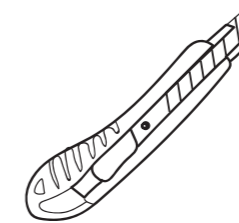
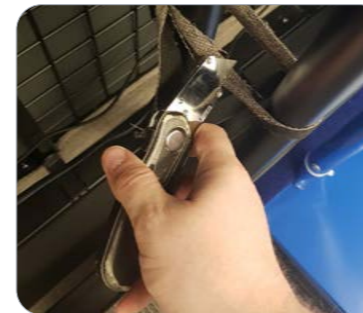

6 Turn bed FACE UP, secure 4 x mattress retainers (side) and 1 x mattress retainer (foot) in place by pushing into allocated slots. Finally, place the mattress onto the bed ensuring all mattress retainers hug the sides and footend.

Side Mattress Retainer



Foot End Retainer

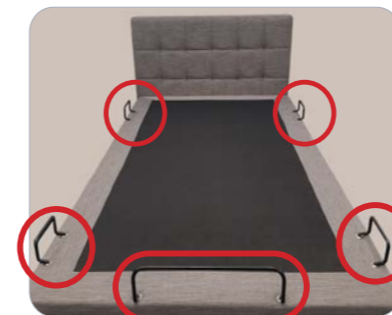

7.2 HEADBOARDS

HOW TO ASSEMBLE OR MOUNT ALLURE / CHESTERFIELD HEADBOARDS

HEADBOARDS	ALLURE (LS) BEA830120	CHESTERFIELD (LS) BEA830100
	ALLURE (KS) BEA830130	CHESTERFIELD (KS) BEA830110

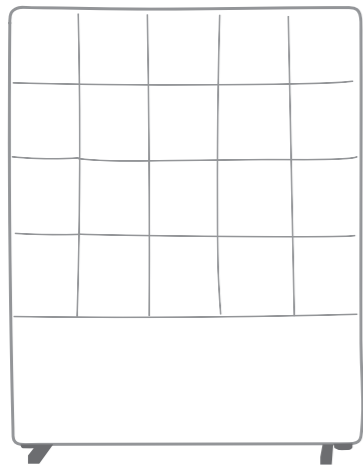

ALLURE
HEADBOARD

OR

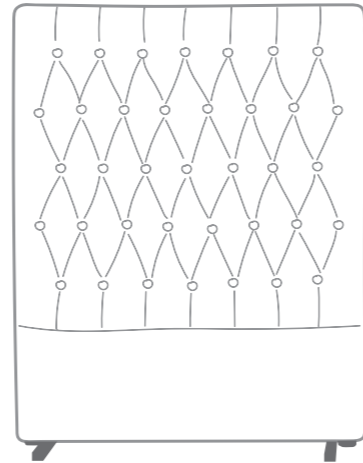

CHESTERFIELD
HEADBOARD

2 X OPTIONS
TO FIT HEADBOARDS

OPTION 1.

FREESTANDING
(WITH STABILISERS)

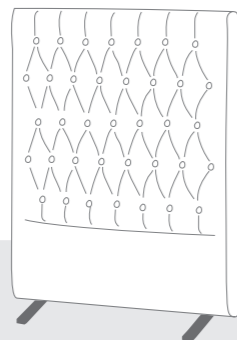

For use on the:

- ✓ LUXE BED
- ✓ CARE BED
- ✓ FIXED COMPANION BED

OPTION 2.

MOUNTED TO BED BASE



For use on the:

- ✓ LUXE BED
- ✗ CARE BED
- ✗ FIXED COMPANION BED

7.2.1 OPTION 1.

HOW TO ASSEMBLE - FREESTANDING WITH STABILISERS

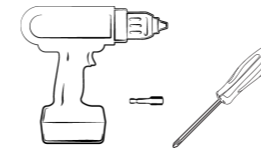

Tools Required:

- Impact driver or drill (5mm attachment)
- Phillips head screw driver (5mm)

For use on the:

- ✓ LUXE BED
- ✓ CARE BED
- ✓ FIXED COMPANION BED



1 Flip headboard upside-down to show the black upholstery.

2 Using the leg stabiliser, align the holes to the white markings. **NOTE:** The short end of the stabiliser should face the back of the headboard (the side that will be positioned against the wall).

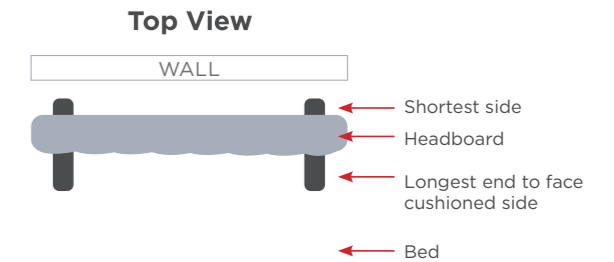

3 Secure the stabilisers in place using the screws provided.



4 Finally, flip the headboard back to its original position, enabling it to stand freely.



7.2.2 OPTION 2. HOW TO MOUNT TO BED

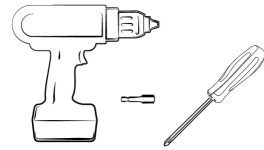

Tools Required:

- Impact driver or drill (5mm attachment)
- Phillips head screw driver (5mm)

NOTE: It is suggested that an impact driver or drill is used to speed up this process. Using a Phillips head screwdriver will work but will take more time. If the impact Driver/Drill has a clutch setting, it should be set to low torque to minimise any risk of bolt misalignment or mount point damage.

NOTE: Headboards can be mounted to the **LUXE Bed only**.

CAUTION: When bed is in raised position, Headboard will raise with bed and poses risk to damaging of fixings or attachments on walls.

For use on the:

- ✓ LUXE BED 
- ✗ CARE BED
- ✗ FIXED COMPANION BED

- 1 Raise bed height, backrest and knee break to maximum height for ease of access.

LUXE Handset



- 2 Locate mounting holes for screw insertion. To locate holes:
 - a. Locate threaded mounting holes (2 per side) at head end of bed.
 - b. Line up bracket over threaded mounting holes and mount in place by rotating phillips head bolt through the top and bottom mounting holes.
 - c. Repeat on both sides, ensuring 4 x bolts (2 per side) are fastened in place.



- 3 When mounting brackets to bed end:
 - a. Line bracket up with foot stopper (on base of headboard).
 - i. Ensure bracket is spaced approx. 40mm from edge of headboard.
 - ii. Ensure bracket is spaced approx. 60mm from base of headboard.
 - b. Through rotation the screw will pierce through the fabric and thread into wood frame (self-tap). Repeat on both sides, ensuring 8x screws (4 per side) are fastened in place.
 - c. Using an impact driver, rotate screw through the upholstery inwards towards frame.
 - d. **NOTE:** Position of bracket should be as per measurements otherwise it will not fit securely to the bed frame.

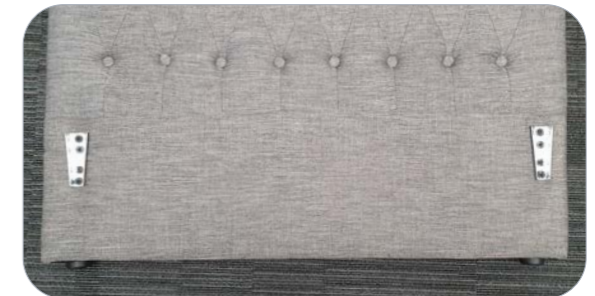

- 4 Align bracket fixings (headboard bracket will slide into bed frame bracket), Slide headboard down until both brackets click into place, the headboard is now in place.

NOTE: Headboard foot supports will rest on the ground when in lowest height.



7.3 ACCESSORIES

HOW TO FIT TO BED BED RAIL / BED STICK

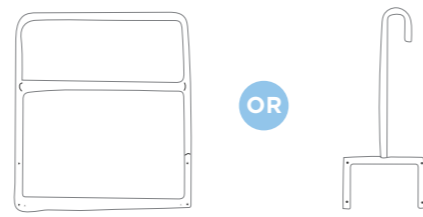

ACCESSORIES

BED RAIL BEA830210

CROOK HANDLE BED STICK BEA830200

For further installation and operating instructions, refer to the **User Manual**.

Tools Required:

- Allen Key (5mm)
- Impact driver or drill (5mm Hex bit attachment)

NOTE: It is suggested that an impact driver or drill is used to speed up this process. If the impact Driver/Drill has a clutch setting, it should be set to low torque to minimise any risk of bolt misalignment or mount point damage.

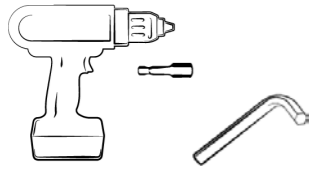

- 1** Adjust bed for simplified installation.
To adjust:

LUXE = 'Press'



CARE = 'Press'



- 2** When fitted, the bed rail or bed stick secures the mattress in place. To avoid collision, the head end mattress retainer should be removed on the side that the bed rail or stick is fitted to.



- 3** ComfiMotion beds have pre-installed mounting points for accessories.

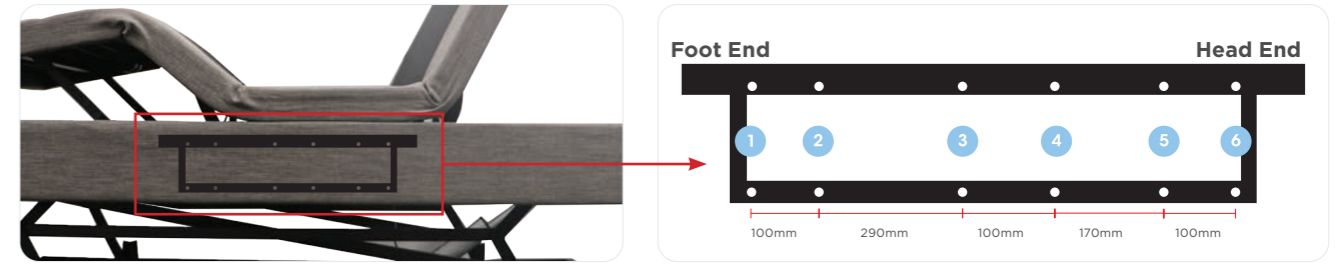

NOTE: Frame not visible through upholstery, for instructional purposes only.

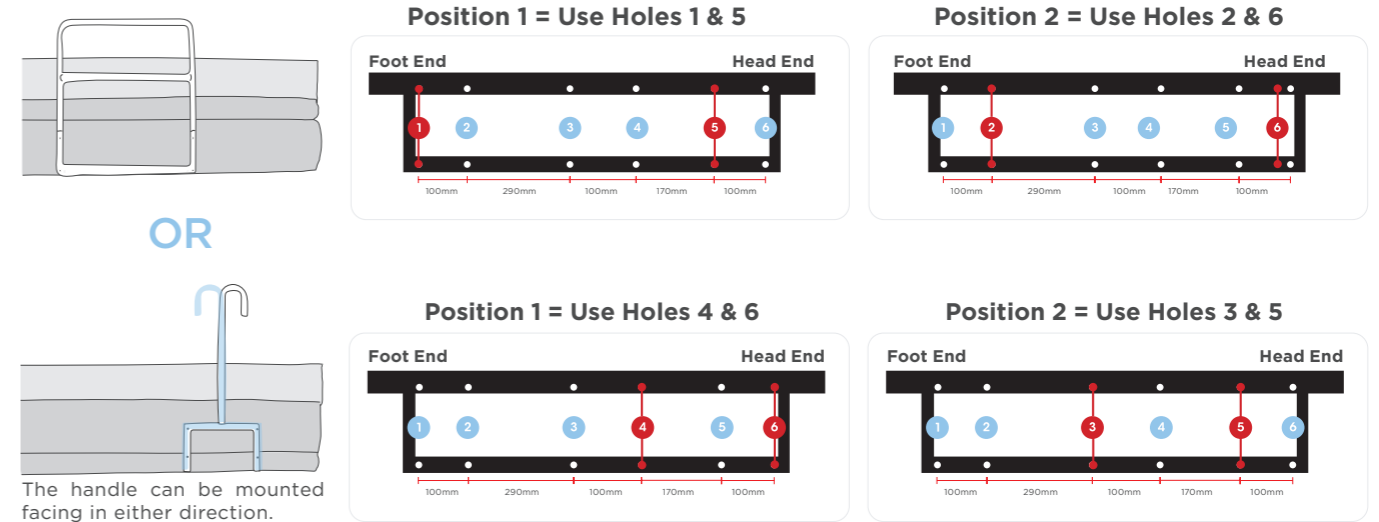

- 4**

a. Locate mounting holes for bolt insertion.
To locate holes: Press on upholstery in line with frame hole and the threaded hole insert can be felt with fingers.

b. Using an impact driver or allen key, rotate bolt through the upholstery inwards towards frame. Through rotation the bolt will pierce through the fabric and thread into pre-installed frame thread.

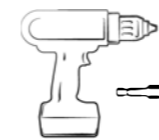

OR



5 After creating your pre-drilled guides (x4 total), remove the bolts from the bed frame to install the rail.

6 Thread the bolt 1, rail 2, and spacer 3 into the pre-drilled hole 4 on each side.

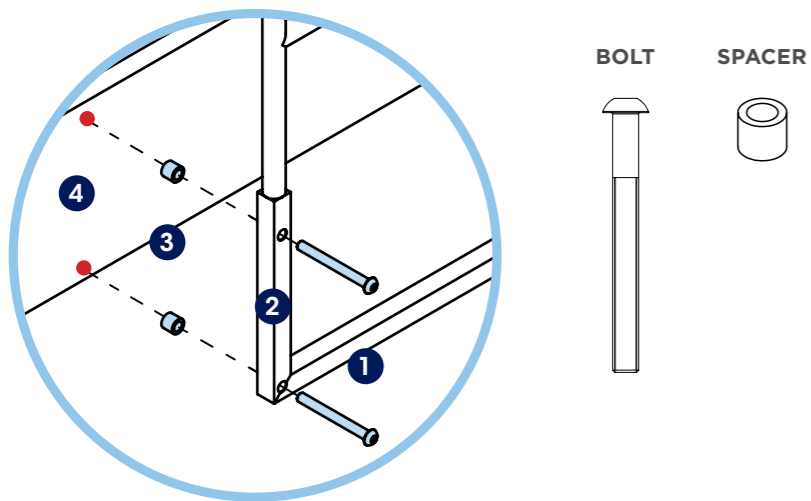

7 Tighten each bolt (x4 total) with a 5mm Allen Key or using an electric drill (with 5mm hex bit), to secure.

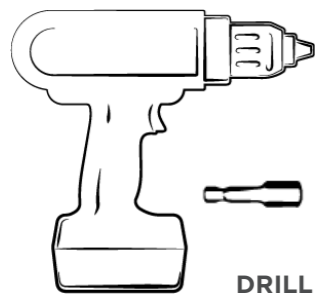

DRILL WITH 5MM HEX BIT



5MM ALLEN KEY

NOTE: As bolts pierce upholstery, holes need to be covered up. If bed rail or pole needs to be repositioned, use (M8 x 60mm) and fasten in place, this will remove the exposed hole and tidy up the side of the bed.

Bolt kits available: Itexm Code: GSP640110.



8. STORAGE & MOVEMENT



- **DISCONNECT** the bed power cord before moving the bed.
- **DO NOT** remove the power cord from the source by pulling on the cord.
- **DO NOT** pull on the power cord, or handset cord to manoeuvre the bed.
- **ALWAYS APPLY THE BRAKES** when the bed is in a stationary position.

HANDLE WITH CARE

- ComfiMotion Beds should be stored in a clean, dry, well ventilated area.
- Do not drop and avoid shock or violent impact when transporting.
- Aidacare offers many bed moving trolley options, please contact us for further information on **1300 133 120** or visit our website at **www.aidacare.com.au**.

COMFIMOTION COMPACT TRANSPORT TROLLEY

Bed frame mechanisms arrive in the box secured with fasteners to minimise loading difficulty and centralise the bed centre of gravity for loading.

KEY FEATURES

- **Tight Turning Radius:** Short wheel base with large low resistance castors make manoeuvring through tight spaces manageable.
- **Reduce Stock Damage:** Padded trolley surfaces protect the fragile upholstery of the bed surround, reducing damage during freight and handling.
- **WHS Outcomes:** Safety strap and lockable castors make loading and unloading the trolley a simple process.

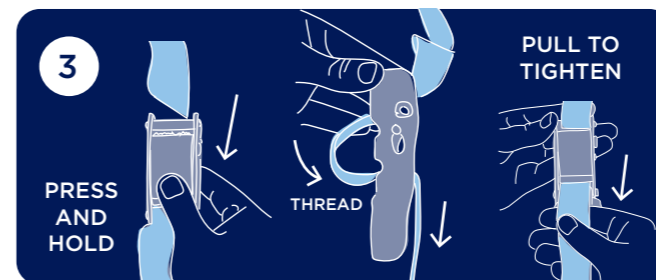
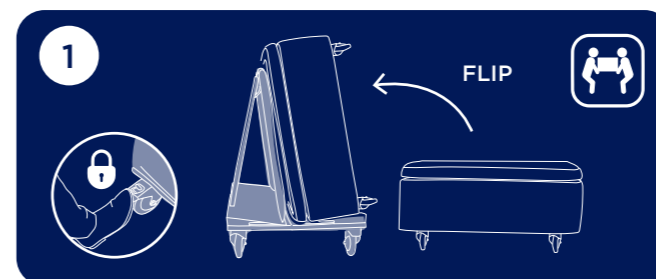

9. CLEANING



BEFORE CLEANING always disconnect the bed from the mains power source.

NOTE: It is strongly recommended that protective clothing be used when cleaning.

NOTE: The following procedure also applies to bed accessories, but does not include mattresses.

- Wipe the beds surfaces with a soft cloth moistened with hot water and mild detergent.
- Rinse with clean water and dry with a clean cloth.
- Ensure bed upholstery is only lightly wiped, it is important not to leave this wet after cleaning.
- Allow the cleaned parts to dry before replacing the mattress.



DO NOT clean with bleach!

10. SERVICE & MAINTENANCE

To prolong the working life of the bed and for trouble free operation it is recommended that routine inspections should be performed by a person who is suitably qualified and well acquainted with the design, use and care of ComfiMotion beds.

If inspection reveals that the safety of the bed is jeopardised in any way, it should be **IMMEDIATELY WITHDRAWN FROM SERVICE**, tagged as such and the owner notified, until repair or replacement has occurred.

INSPECTION:

- A visual and functional inspection should be performed monthly
- Visually inspect electrical components: can you see damage to the hand control or power cord?
- Visually inspect mechanical components: can you see damage, chips or deformation to the frame, headboard or accessories?
- Is the hand control functioning as it should?
- Are the castors, brakes and accessories functioning as they should?

PREVENTATIVE MAINTENANCE:

The following preventative maintenance procedures should be carried out every 12 months or as otherwise specified:

NOTE: Other than general maintenance activities all other service or repair work must be performed by qualified and trained persons or agents approved by Aidacare.

- Overall functional check that all hand control functions are operating the bed as expected.
- Overall inspection for visible signs of wear, tear or damage to the integrity of electronics and Cables.
- Actuators and all moving components should not make unusual noises.

NOTE: If you are unsure if your ComfiMotion bed is working correctly, Contact Aidacare or your local authorised Aspire Dealer.

11. TROUBLESHOOTING

Effect	Possible Cause	Verification	Corrective Action
BED DOES NOT STAY IN PLACE	Locking castors not preventing bed movement.	Not all locking castors have been engaged.	Engage all 4 x locking castors on each corner of the bed.
	Brake System is malfunctioning.	Brake pedal is in lowest position, but bed does not stay in place.	If this does not work, contact your sales representative or a qualified Aidacare service technician.
BED DOES NOT MOVE UP OR DOWN	Bed is not plugged in and optional battery is flat.	Check if the power lead is plugged into mains power.	If unplugged, plug power leads into mains power. Allow 3 hours to charge battery (if fitted).
	Actuator is faulty. Handset is faulty.	Swap actuators. Swap handsets.	Contact your sales representative or a qualified Aidacare service technician.
BACKREST DOES NOT MOVE UP OR DOWN	Actuator code is unplugged. Actuator is faulty. Handset is faulty.	Check if cables have come loose from control box (under top frame at head end). Swap Actuator. Swap handsets.	If loose, fully plug cables into control box. Contact your sales representative or a qualified Aidacare service technician.

12. WARRANTY & SERVICE

Aspire ComfiMotion Beds carry a comprehensive warranty as detailed below. Please keep proof of purchase for proof of warranty commencement.



Frame



Electronics



Handset and Cables

Consumer Warranty Against Defects:

Aidacare is bound by Australian Consumer Law in respect to Warranty Against Defects. A copy of the Aidacare Warranty Against Defects statement is available on the Aidacare homepage at www.aidacare.com.au. All warranty matters should be directed to Aidacare Customer Service on 1300 133 120.

Aidacare does not warrant against excessive or incorrect use, modification or any situation that could not be deemed as fair wear and tear. This is a back to base warranty and does not cover freight costs pertaining to the return of any items under warranty. Aidacare acknowledges and conforms to all ACCC guidelines around consumer rights. For further information contact Aidacare on 1300 133 120 or email product@aidacare.com.au.

Aidacare will not warrant the safety and or correct functioning of products where any original components have been changed or modified by non-Aidacare approved and trained service & maintenance staff or external providers. Furthermore, safety is not guaranteed where components have been replaced with non-original Aidacare approved parts. If any faults are detected upon receipt of this product please phone Aidacare. Any faults that are detected during normal use should be reported to Aidacare immediately to determine if warranty conditions apply and if so, the necessary repair or replacement work to be completed.

Spare parts list is available upon request.

For servicing, preventative maintenance and any other questions regarding this or any other Aidacare product please contact:

Aidacare Pty Ltd
 Building 3A, 1 Moorebank Avenue
 Moorebank NSW, 2170
 T - 1300 133 120
 W - www.aidacare.com.au
 E - product@aidacare.com.au

13. SERVICE LOG BOOK

YEAR 1

Date: _____
Service Type: _____
Condition Report: _____

Inspected by: _____ Signature: _____
Action taken: _____
_____ Date: _____

YEAR 2

Date: _____
Service Type: _____
Condition Report: _____

Inspected by: _____ Signature: _____
Action taken: _____
_____ Date: _____

YEAR 3

Date: _____
Service Type: _____
Condition Report: _____

Inspected by: _____ Signature: _____
Action taken: _____
_____ Date: _____

YEAR 4

Date: _____
Service Type: _____
Condition Report: _____

Inspected by: _____ Signature: _____
Action taken: _____
_____ Date: _____

YEAR 5

Date: _____
Service Type: _____
Condition Report: _____

Inspected by: _____ Signature: _____
Action taken: _____
_____ Date: _____

YEAR 6

Date: _____
Service Type: _____
Condition Report: _____

Inspected by: _____ Signature: _____
Action taken: _____
_____ Date: _____

YEAR 7

Date: _____
Service Type: _____
Condition Report: _____

Inspected by: _____ Signature: _____
Action taken: _____
_____ Date: _____

YEAR 8

Date: _____
Service Type: _____
Condition Report: _____

Inspected by: _____ Signature: _____
Action taken: _____
_____ Date: _____

YEAR 9

Date: _____
Service Type: _____
Condition Report: _____

Inspected by: _____ Signature: _____
Action taken: _____
_____ Date: _____

YEAR 10

Date: _____
Service Type: _____
Condition Report: _____

Inspected by: _____ Signature: _____
Action taken: _____
_____ Date: _____

AIDACARE PTY LTD

Building 3A, 1 Moorebank Avenue,
Moorebank NSW Australia 2170

1300 133 120 | www.aspirecare.com.au

MADE IN PRC

